



P.A. - S.p.A. - EQUIPAGGIAMENTI TECNICI DEL LAVAGGIO

VIA MILANO, 13 - CASELLA POSTALE 115 - 42048 RUBIERA (REGGIO EMILIA) - ITALY
 Tel. +39 0522 623611 - Fax. +39 0522 629600 - R.E.A. RE 156319 - R. I. RE 11535 - Mecc. RE 013446
 C.F. e P. IVA 01035950359 - Cap. Soc. i.v. € 750.000,00 - Codice Identificativo C.E.E. IT 01035950359
 ART. 2497 - BIS C.C. DIREZIONE E COORDINAMENTO BENETTI srl R.I. TRIB. DI RE 01480690351
<http://www.pa-etl.it> - E-mail: info@pa-etl.it



VB 280-VB350 - Unloader Valve (discharging)

Technical manual: **E 237**

Pressure regulating unloader valve.
 At gun shut off, the water flow is bypassed at reduced pressure.

DN 10



- **60.1600.00** VB 280 G 3/8 MF **CE**
- **60.1700.00** VB 350 G 3/8 MF

- Assembly equipped with a high pressure proof compensation.
- Compact dimensions.
- Sturdy steel and brass construction.
- Adjustable locknut to control max pressure.
- Possibility to fit a venturi injector, on delivery, for chemicals.
- Nylon knob
- By-pass G1/2 F.
- Easy maintenance.

Technical specifications

Part Number	Rated pressure	Permissible pressure	Minimum adjustable pressure	(2)Trapped pressure at circuit closure	(3)Pressure drop to reset bypass	Inlet Outlet bypass	Weight
	bar - MPa						
60.1600.00	280 - 28	310 - 31	28 - 2.8	12	44	G3/8 MF	850
60.1700.00	350 - 35	390 - 39	35 - 3.5	12	44	G3/8 MF	880

(1) The valve has been designed for a continuous use at a water temperature of 60°C. It can resist for short periods at a maximum temperature of 90°C.

(2) This is the maximum pressure increase implemented in the circuit for the intervention of the valve and to bring all the fluid in bypass (percentage figures of the pressure set up)

(3) This is the pressure reduction necessary in comparison to the set up, in order that the valve brings back pressure in the circuit. (percentage figures of the pressure set up)

Instruction manual, maintenance, installation, spare parts.	n. 12.9237.00
For a correct utilization, follow the directions of this manual Re-print them on the Use and Maintenance booklet of the machine.	

DIMENSIONAL DRAWING

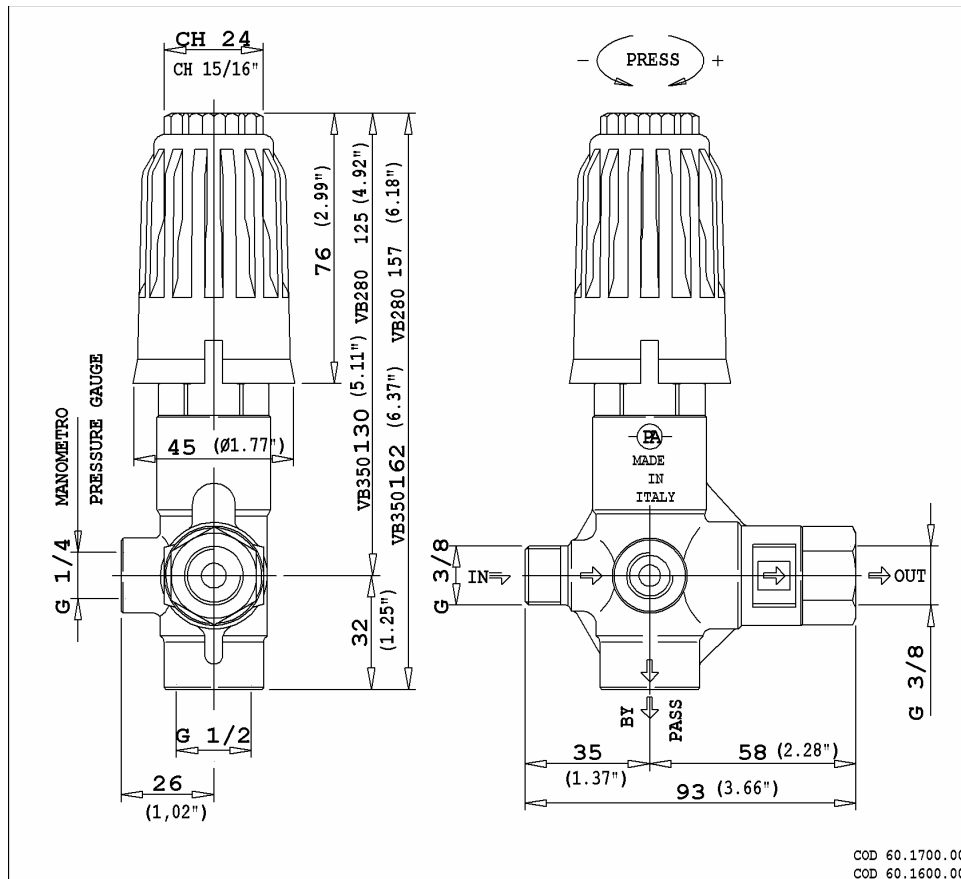

INSTRUCTIONS

SELECTION

This product is to be utilized with clean fresh water, even slightly additivated with normal detergents. For use involving different or corrosive liquids, contact the PA Technical department. Appropriate filtration should be installed when using unclean liquids. Choose the valve in line with the data of nominal running (system rated pressure, max flow and max temperature). In any case, the pressure of the machine should not exceed the permissible pressure rate imprinted on the valve.

INSTALLATION

This accessory, on a system that produces hot water, must be fitted in **front of the heat generator**. This product is bound to be incorporated on a finished machine. On a system that generates hot water, anticipate the fitting of accessories that limit the accidental increase of fluid temperature.

Always install a safety valve that protects the pressurized outlet channel.

Choose a correct nozzle size, which allows a regular discharge on bypass, at least 5% of the total flow of the system in order to achieve a constant pressure value and avoid troublesome pressure spikes at closure. If the nozzle wears out, the pressure drops.

On installation of a new nozzle, re-adjust the system to the original pressure setting

OPERATIONS

The valve regulates the the max pressure of the system through a piston, which acts on a ball that, normally positioned, closes the bypass opening. A check valve cuts out the delivery section, the pressure of which controls the drive of the piston.

Each regulation should be made when the system is operational and the nozzle open.

ATTENTION: The nut (pos.15) must never be removed mainly because, it is a mechanical safety feature that limits the max pressure and avoids serious damage to persons and machine.

DISCHARGE SYSTEM AND WATER ADDUCTION

The bypass line should be returned into a tank with deflectors. With elevated pressure intake, it is necessary to install a pressure reducer in order to have an even flow supply and to protect the circuit intake.

When the system is opened and closed frequently, it is recommended to install a thermal protector valve (VT3 or VT6) in order to eliminate excessive temperature build.

PROBLEM HANDLING: CAUSES AND SOLUTIONS

PROBLEMS	PROBABLE CAUSES	SOLUTIONS
Frequent unloader recycles	Damaged check valve O-Ring Leaking connections Restricted bypass	Replace Check and renew Clean or adapt
Unloader does not reach pressure	Unloader not properly sized Piston O rings worn out Material matter between seat and shutter Worn out nozzle	Change spring or type of valve Replace Clean the seat Replace
Pressure peaks	Less than 5% of total flow in bypass Excessive flow in bypass Spring totally compressed	Reset Change type of valve or adjust passages Loosen knob and change nozzle
Unloader does not bypass at low pressure	Jammed check valve Check valve O ring worn out Material matter on check valve	Clean or replace Replace Clean
Unloader causes oscillations to the hydraulic system	Bypass system unfit Bypass tube not properly sized Bypass obstructed or throttled	Stick to the installation scheme represented at the bottom of this page, with bypass directed into the pump Enlarge diameter Clean or reset

REGULATIONS : *see provisional manual*

The accessory hereby described bears the CE mark in compliance with provisions and regulations indicated on the **Declaration of conformity**.

For a correct utilization, follow the directions described in this manual and re-print them on the Use and maintenance manual of the machine.

Make sure that you are given the **Original Declaration of Conformity** for the accessory chosen. The present manual is valid for all unloader valves type **VB 280** and **VB 350**.

MAINTENANCE

Maintenance has to be carried out by **Specialized Technicians**.

STANDARD: every 400 working hours (circa 10,000 cycles), control and lubricate the seals with water resistant grease.

SPECIAL: every 800 working hours (circa 20,000 cycles), control the wear of the seals and internal parts and if necessary, replace with original PA parts taking care during installation and to lubricate with water resistant grease.

ATTENTION: reassemble the valve in the correct manner paying special attention to the Nut (pos 19) which must always be in place.

The manufacturer is not to be considered responsible for damage as a result from incorrect fitting and maintenance-

Technical data, descriptions and illustrations are indicative and liable to modification without notice

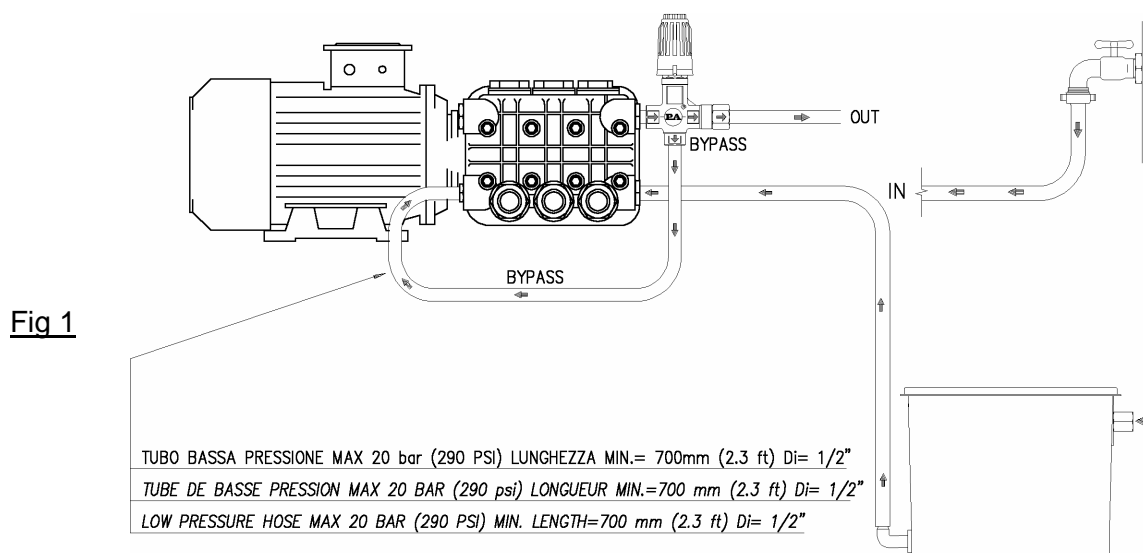

60.1600.00 VB280 unload. 3/8MF Bsp byp:1/2F+knob
 60.1700.00 VB350 unload. 3/8MF Bsp byp:1/2F+knob

60.1700.50 VB350 unload. 3/8MF Npt byp:1/2F+knob

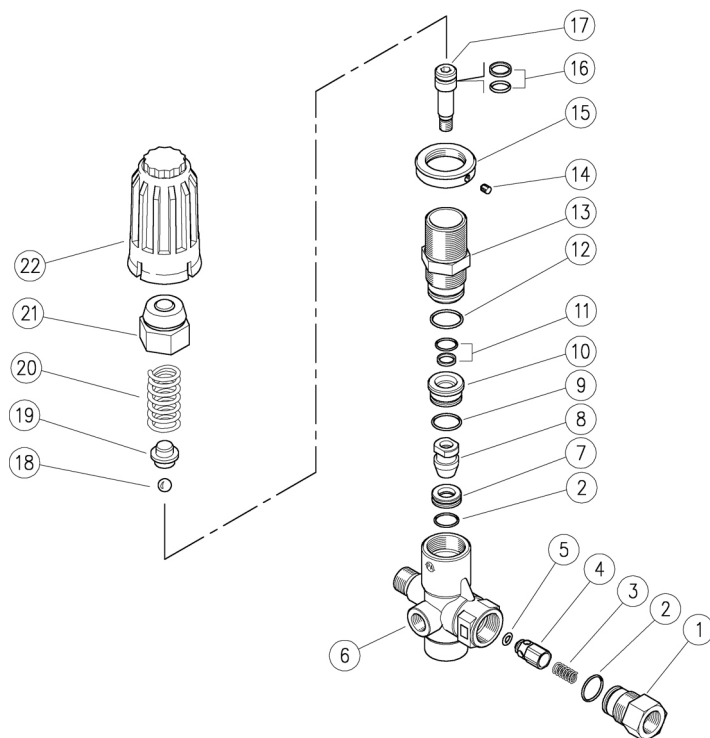

Pos.	P/N	Description	Q.ty	K1	K2	K3	K4	
1	60.1811.31	Shutter coupl., 3/8F Bsp brass	1					3
1	60.1817.31	3/8Npt F nipple (1)	1					3
2	10.3066.01	O-ring, 1,78x15,6 mm Ni 85	2	•				10
3	60.0053.51	Spring, 0,7x9x20 mm Sst.	1					10
4	60.9052.93	Shutter pin, Sst.+or 3x6 mm N90	1					10
5	10.3213.08	O-ring, 3x6 mm Ni 90	1	•				10
6	60.1725.35	Hous.-V280-350/4,3/8M c/snk+1/4F Bsp brs	1					3
6	60.1717.35	Hous.-V280-350/4,3/8M Npt +1/4FNpt brs (1)	1					3
7	60.1809.51	Seat, 11,6x19x6 mm Sst.	1	•				5
8	60.1808.51	Shutter pin, M8 Sst.	1	•				3
9	10.3068.01	O-ring, 1,78x17,17 mm Ni 85	1	•				10
10	60.1810.31	Spacer ring, 10,3x23,4x12,5 mm brass	1					5
11	60.0979.24	Stem seal, 10x14,9x2,2 mm+O-ring	1	•				5
12	10.3072.01	O-ring, 1,78x20,35 mm Ni 85	1	•				10

Pos.	P/N	Description	Q.ty	K1	K2	K3	K4	
13	60.0973.31	Piston holder, brass (2)	1					3
13	60.1805.31	Piston holder, brass (3,1)	1					3
14	16.2100.00	Set screw, DIN914 M4x4 mm	1					10
15	60.1728.31	Ring nut, M27x1 brass	1					3
16	60.0978.24	Piston seal, 9x14x2,2 mm+O-ring	1	•				5
17	60.1806.51	Piston, M8 Sst.	1					3
18	14.7443.10	Ball, 11/32" Sst.	1	•				10
19	60.1813.31	Spring rest pin, brass	1					5
20	60.0975.61	Spring, 4,2x19,7x42 mm z.pl. (2)	1					10
20	60.1812.61	Spring, 4,5x15,8x47mm (3,1)	1					3
21	60.1727.31	Valve regulating insert, brass	1					5
22	60.1726.84	Valve regulating knob, PA black (2)	1					10
22	60.1729.84	Valve regulating knob, PA red (3,1)	1					10

Kit	P/N	Description	
K1	60.1615.24	Spares kit -VB280-350/4 11x1pcs.	1

(1) 60.1700.50 (2) 60.1600.00 (3) 60.1700.00



P.A. - S.p.A. - EQUIPAGGIAMENTI TECNICI DEL LAVAGGIO

VIA MILANO, 13 - CASELLA POSTALE 115 - 42048 RUBIERA (REGGIO EMILIA) - ITALY
 Tel. +39 0522 623611 - Fax. +39 0522 629600 - R.E.A. RE 156319 - R. I. RE 11535 - Mecc. RE 013446
 C.F. e P. IVA 01035950359 - Cap. Soc. i.v. € 750.000,00 - Codice Identificativo C.E.E. IT 01035950359
 ART. 2497 - BIS C.C. DIREZIONE E COORDINAMENTO BENETTI srl R.I. TRIB. DI RE 01480690351
<http://www.pa-etl.it> - E-mail: info@pa-etl.it



VB 350 – with micro switch



Technical manual: E 236

Pressure regulating valve connected to an electric switch, electro-mechanic type, which when reaching a preset calibrated pressure, opens or closes an electric contact.

At gun shut off, the water flow is bypassed at reduced pressure

DN 10



- **60.1730.00** VB 350 with micro G3/8 MF
 - Sturdy construction in steel and brass
 - Electrical insulation: class IP55
 - Electric drive shunted from valve functions with two positions:
 - 1) Unloader working in pressure
 - 2) Unloader with all the flow in bypass
 - Mechanical control of the electric switch for a simple and reliable function.
 - Hexagonal shaped check valve to avoid jamming.
 - Rotating by-pass manifold G3/8 F.

Technical specifications

Part Number	Rated pressure	Permissible pressure	Minimum adjustable pressure	(2)Trapped pressure at circuit closure	(3)Pressure drop to reset bypass	Inlet Outlet	Weight
	Max. flow rate: 40 l/min. Max temperature: 90°C (1)						
60.1730.00	350 - 35	390 - 39	35 – 3.5	8	43	G3/8MF	970

(1) The valve has been designed for a continuous use at a water temperature of 60°C. It can resist for short periods at a maximum temperature of 90°C.

(2) This is the maximum pressure increase implemented in the circuit for the intervention of the valve and to bring all the fluid in bypass (percentage figures of the pressure set up)

(3) This is the pressure reduction necessary in comparison to the set up, in order that the valve brings back pressure in the circuit. (percentage figures of the pressure set up)

TECHNICAL SPECIFICATIONS OF THE MICRO SWITCH

Max rated voltage: 250 V
 Breaking switch: 6 (A) – resistive load - 6 (A) – inductive load
 Cable length : 1200 mm – electric wire : 3 x 1 mm²
 Cable max ampere: 10 A
 Environment temperature: 75 °C – Type of action: 1C
 Electrical component life: 50.000 commutations, T.85°C, a 250V in line with CEE 24- VDE 0630
 Pollution situation of the device control: High

Instruction manual, maintenance, installation, spare parts	n. 12.9236.00
For a correct utilization, follow the directions of this manual	
Re-print them on the use and Maintenance booklet of the machine.	

DIMENSIONAL DRAWING

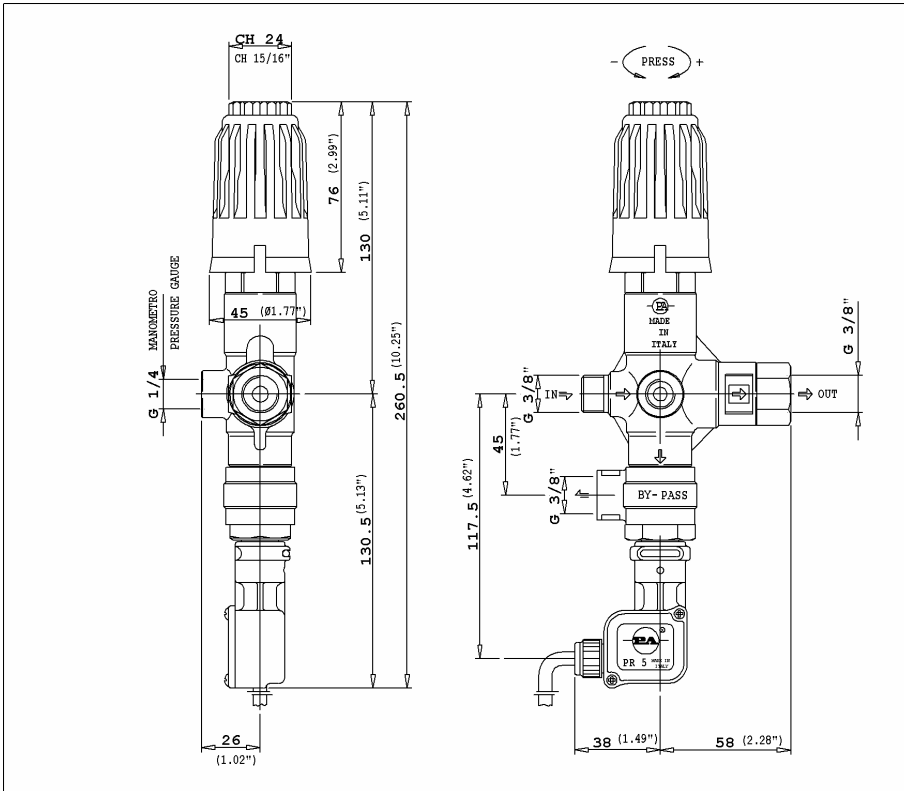

INSTRUCTIONS

SELECTION

This product is to be utilized with clean fresh water, even slightly additivated with normal detergents. For use involving different or corrosive liquids, contact the PA Technical department. Appropriate filtration should be installed when using unclean liquids. Choose the valve in line with the data of nominal running (system rated pressure, max flow and max temperature). In any case, the pressure of the machine should not exceed the permissible pressure rate imprinted on the valve.

The technical and mechanical specifications, (pressure) described on the cover of the microswitch are not to be considered valid.

INSTALLATION

This accessory, on a system that produces hot water, must be fitted in front of the heat generator. This product is bound to be incorporated on a finished machine. On a system that generates hot water, anticipate the

fitting of accessories that limit the accidental increase of fluid temp.

Always install a safety valve that protects the pressurized inlet channel.

Choose a correct nozzle size, which allows a regular discharge on bypass, at least 5% of the total flow of the system in order to achieve a constant pressure value and avoid troublesome pressure spikes at closure. If the nozzle wears out, the pressure drops. On installation of a new nozzle, re-adjust the system to the original pressure setting. Electrical installation must be carried out by qualified personnel

ATTENTION: Always assure a correct earthing to this electric device

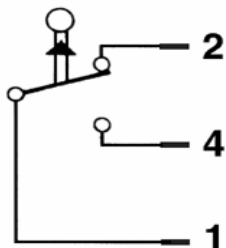

WIRING DIAGRAM

- 1) Red wire - 2) Blue wire - 4) Brown wire

ELECTRICAL CONNECTION

- N.O. Red + Brown – Normally open
- N.C. Red + Blue – Normally closed

OPERATIONS

The valve regulates the max pressure of the system through a piston, which acts on a ball correctly positioned, that closes the bypass opening. A check valve cuts out the delivery section, the pressure of which controls the drive of the piston. Each regulation should be made when the system is operational and the nozzle open. In order not to overstep the max pressure, the nut pos 15 must be fastened securely. Mark the position with a drop of paint in order to prevent possible slackening and tampering. The balanced conformation of the valve allows a renewed pressure at very low readings giving a longer function in bypass and a progressive start, without unpleasant pressure spikes, useful with endothermic engines.

ATTENTION: The nut (pos.15) must never be removed otherwise a mechanical safety feature that limits the max pressure will lack, avoiding serious damage to persons and machine.

DISCHARGE SYSTEM AND WATER ADDUCTION

The bypass line should be returned into a tank with deflectors. By using a direct pump recycle, with elevated pressure intake, it is necessary to install a pressure reducer in order to have an even flow supply and to protect the circuit intake. When the system is opened and closed frequently, it is recommended to install a thermal protector valve (VT3 or VT6) in order to eliminate excessive temperature build-up. It is advisable to fit, for the bypass line direct to the pump, an appropriate sized hose of at least 250mm length.

PROBLEMS AND SOLUTIONS

PROBLEMS	PROBABLES CAUSES	SOLUTIONS
Frequent unloader recycles	Damaged check valve O ring Leaking connections Restricted bypass	Replace Check and renew Clean or adapt
Unloader vibrates at lance aperture	Too much fluid in discharge, probably more than 30% of the pump flow rate.	Unadequate nozzle. Replace with one that has superior flow rate.
Imperfect electric signal	Loose wires Short control pin	Reconnect Adjust nut and ball holder
Unloader does not reach pressure	Unloader not properly sized Piston O rings worn out Material matter between seat and shutter Worn out nozzle	Change spring or type of valve Replace Clean the seat Replace
Pressure peaks	There is not a min of 5% of total flow in bypass Excessive flow in bypass Spring totally compressed	Reset Change type of valve or adjust passages Loosen knob and change nozzle
Unloader does not bypass at low pressure	Jammed check valve Check valve O ring worn out Material matter on check valve	Clean or replace Replace Clean

REGULATIONS : *see norm manual*

The accessory hereby described bears the CE marking in accordance with the Norms and Directives applied on the Declaration of conformity.

For a correct utilization, follow the directions described in this manual and re-print them on the Use and maintenance manual of the machine.

Make sure that you are given the **Original Conformity Declaration** for the accessory chosen. The present manual is valid for all unloader valves named **VB350 with micro switch**

MAINTENANCE

Maintenance has to be carried out by **Specialized Technicians.**

STANDARD: every 400 working hours (circa 10,000 cycles), check and lubricate the seals with water resistant grease.

SPECIAL: every 800 working hours(circa 20,000 cycles), control the wear of the seals and internal parts and if necessary, replace with original PA parts taking care during installation and to lubricate with water resistant grease.

ATTENTION: reassemble the valve in the correct manner paying special attention to the Nut (pos 15) by fastening it with a drop of a strong glue.

The manufacturer is not to be considered responsible for damage as a result from incorrect fitting and maintenance

Technical data, descriptions and illustrations are indicative and liable to modification without notice.

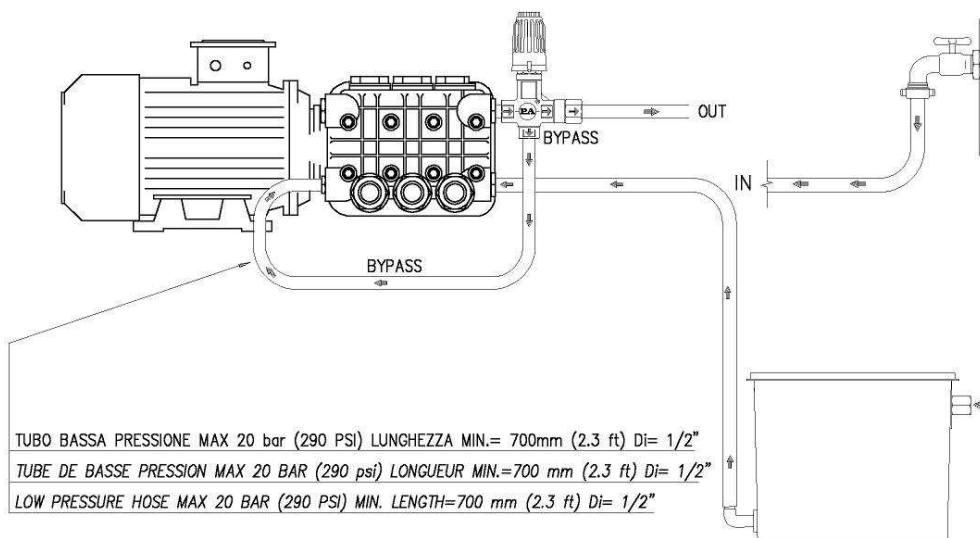
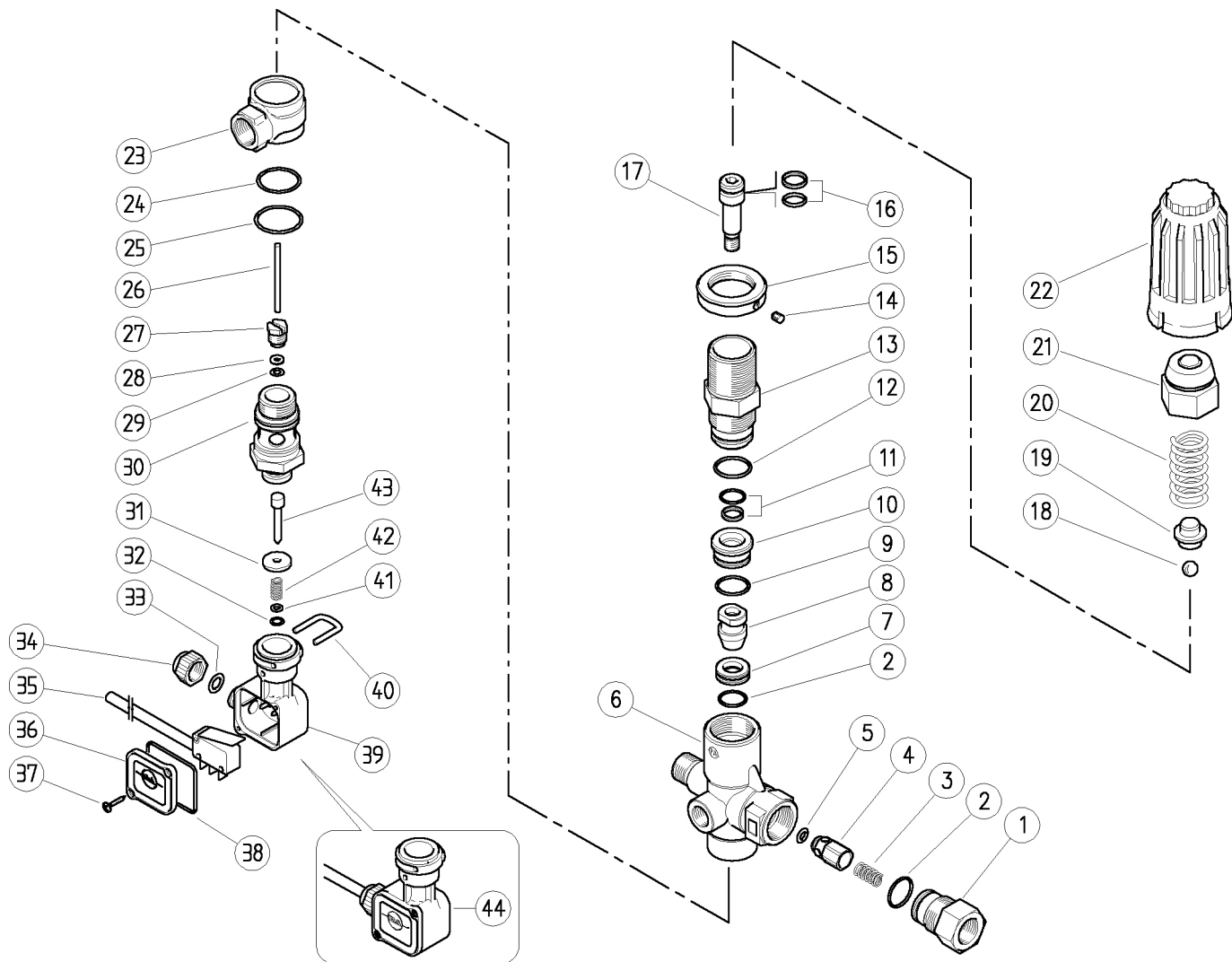

Fig.1

60.1730.00 VB350 unld.3/8F Bsp port:3/8M+m/sw+knob



Pos.	P/N	Description	Q.ty	K1	K2	K3	K4		Pos.	P/N	Description	Q.ty	K1	K2	K3	K4	
1	60.1811.31	Shutter coupl., 3/8F Bsp brass	1					3	23	60.0733.35	Valve manifold, brass	1					3
2	10.3066.01	O-ring, 1,78x15,6 mm Ni 85	2	•				10	24	10.3072.50	O-ring, 1,78x21,95 mm	1	•				10
3	60.0053.51	Spring, 0,7x9x20 mm Sst.	1					10	25	10.3073.00	O-ring, 1,78x23,52 mm	1	•				10
4	60.9052.93	Shutter pin, Sst.+or 3x6 mm N90	1					10	26	60.1733.51	Micro-switch piston, Sst.	1					5
5	10.3213.08	O-ring, 3x6 mm Ni 90	1	•				10	27	60.1732.31	Plug, M10x1 brass	1					10
6	60.1725.35	Hous.-V280-350/4, 3/8M c/snk+1/4F Bsp brs	1					3	28	10.4018.00	Back-up ring, 3,2x7,5x1,2 mm	1					10
7	60.1809.51	Seat, 11,6x19x6 mm Sst.	1	•				5	29	10.3165.00	O-ring, 2,62x2,84 mm Vi 70	1	•				10
8	60.1808.51	Shutter pin, M8 Sst.	1	•				3	30	60.1731.31	Seat holder, 1/2M Bsp brass	1					5
9	10.3068.01	O-ring, 1,78x17,17 mm Ni 85	1	•				10	31	29.0086.31	Washer, 4x16x2,5 mm brass	1					10
10	60.1810.31	Spacer ring, 10,3x23,4x12,5 mm brass	1					5	32	10.3038.00	O-ring, 1,78x3,68 mm	1	•				10
11	60.0979.24	Stem seal, 10x14,9x2,2 mm+O-ring	1	•				5	33	10.3169.00	O-ring, 2,62x6,02 mm	1	•				10
12	10.3072.01	O-ring, 1,78x20,35 mm Ni 85	1	•				10	34	29.0082.84	Locknut for cable gland, PA black	1					10
13	60.1805.31	Piston holder, brass	1					3	35	12.5006.00	Cable, 3x0,75 L.1000 mm+ Microswitch	1					5
14	16.2100.00	Set screw, DIN914 M4x4 mm	1					10	36	29.0088.84	Lid, PR5 PA black	1					10
15	60.1728.31	Ring nut, M27x1 brass	1					3	37	16.3020.00	S/tapp. screw, 2,5x12mm chrom	2					10
16	60.0978.24	Piston seal, 9x14x2,2 mm+O-ring	1	•				5	38	10.3206.01	O-ring, 2,62x28,25 mm	1	•				10
17	60.1806.51	Piston, M8 Sst.	1					3	39	29.0089.84	Housing, PR5 PA black	1					10
18	14.7443.10	Ball, 11/32" Sst.	1	•				10	40	29.0087.51	U-bolt, Sst.	1					10
19	60.1813.31	Spring rest pin, brass	1	•				5	41	14.3519.00	Washer, 4x8x0,5 mm brass	1					10
20	60.1812.61	Spring, 4,5x15,8x47mm	1					3	42	60.2303.51	Spring, 1,1x8x20 mm Sst.	1					10
21	60.1727.31	Valve regulating insert, brass	1					5	43	60.2351.31	Micro-switch piston, brass	1					10
22	60.1729.84	Valve regulating knob, PA red	1					10	44	29.0096.24	Casing kit -PR5, complete 40bar	1					5

Kit	P/N	Description	Q.ty
K1	60.1736.24	Spares kit -VB350+PR5, 18x1pcs.	1